

S100-MG Sail Winch

Product Drawing

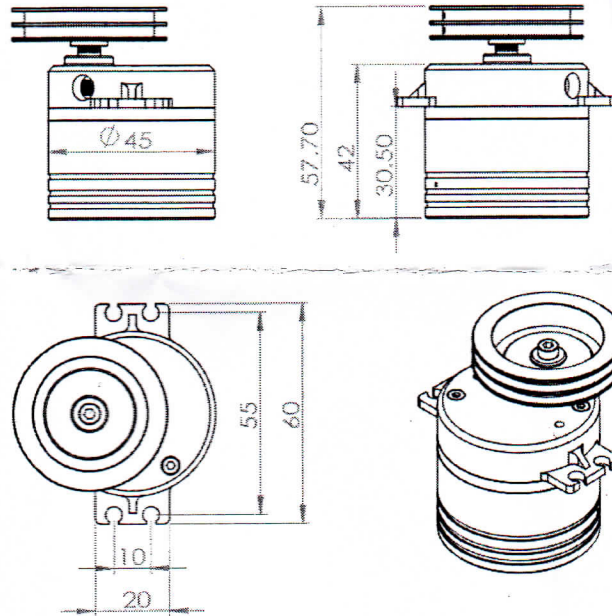

Specification

Voltage(V)	No-Load current(A)	Stall current (A)	No-load running Speed	Stall torque KG/cm
4.80	0.40	2.80	0.115s/60°	13
6.00	0.43	3.60	0.095s/60°	17
7.40	0.45	4.00	0.075s/60°	19
8.40	0.50	4.90	0.07s/60°	22

Product Feature

- Waterproof IP68/360 degree 4 cycle/Light weight 108g.
- High performance / high efficiency Brushless Motor.
- Large torque /High speed /metal gear/Metal housing/Dual ball bearing.
- Wide voltage use /4096 Pixel resolution.